

CLOUD BASED SMART WATER METER

Rugvedi Deshmukh, Vrushali Bankar, Vaishnavi Bandagale, Amruta doiphode.

Abstract— This is a research paper on WATER METER which has become a notable topic in today's technological discussion. In this fast paced life water suppliers and consumers needs to introduce a new water system which is more efficient and comparatively quicker. Digital Water Meters are used to measure the volume of water used by residential and commercial buildings that are supplied with water by a public water supply system. Thus by using this we can keep monitoring on the usage of water by different consumers. The main objective is to make water supply more accountable and transparent which reduces the manual assistance, deliver secure and time efficient solution for the complex water system. Apart from grown countries, the water supplies in others present with a sensor which is operated electronically. In this project a GSM based billing system is provided. This is a system which leads to a continual hassle free water supply and billing giving maximum convenience to consumers and enhancement in water usage audit.

Index Terms— Flow Sensor, GSM, IOT,

1.1 INTRODUCTION

In many parts of the world analogue water meters have been installed by water companies to measure the consumers water consumption. These water meters are read on a monthly basis by an authorized employee and the consumers bill is computed based on the approved rates according to the amount of water consumed. Sometimes the customer premises are not easily accessible and consumption estimates have to be used in computation of the water bill. This is error prone as accuracy cannot be guaranteed. This method of manual data collecting is also expensive, labour intensive and hence inefficient.

Smart water systems can serve as alternatives to overcome the shortcomings of manual metering systems. They are wireless sensor networks which can be installed in thousands of households to collect periodic measurements that are reported in real-time. Water metering is the process of measuring water use. There are two basis of measuring flow, these are volumetric basis and weight basis. The basic relationship of sectional area of the pipe and the average velocity of the flow. The other factors that affect liquid flow rate include the liquid's viscosity, density and the friction of the liquid in contact with the pipe. Flow sensor based water meter presents very low cost, reliable, quick water meter system accompanying with existing GSM networks. Monthly water usage can be sent to municipal corporation office within fraction of seconds in the form of text message by using existing GSM network. Such metering system reduces manpower, with higher accuracy and less power consumption.

1.2 Existing System

The water supply system varies from urban to rural areas. In metropolitan cities, water is available 24*7 and in urban and rural area water supply is available only for 2- 3hrs. In many parts analogue water meters have been installed by water companies to measure the consumer's water consumption. These water meters are read on a monthly basis by an authorized employee and the consumer's bill is computed based on the approved rates according to the amount of water consumed. Sometimes the customer premises are not easily accessible and consumption estimates have to be used in computa-

tion of the water bill. This method of manual data collecting is also expensive, labour intensive.

At intermediate level, the billing of society, complex water consumption is then divided into at individual home, block which is not based on consumption on individual's water usage.

2 REQUIREMENT ANALYSIS

2.1 Block Diagram

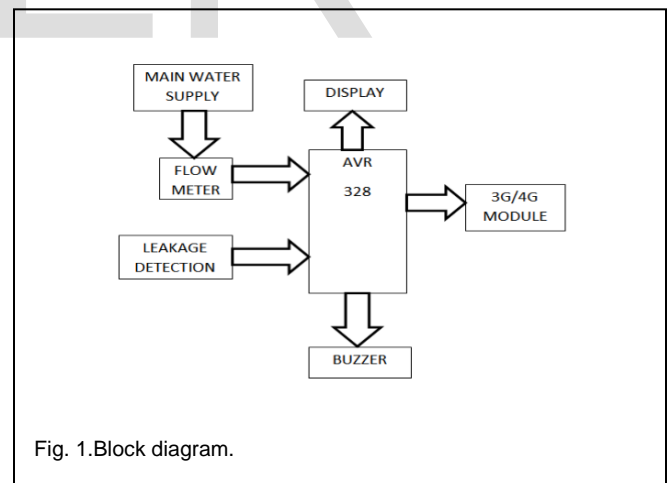

Fig. 1. Block diagram.

2.2 Hardware

ATmega328- The high-performance Atmel pico Power 8-bit AVR RISC-based microcontroller combines 32KB ISP flash memory with read-while-write Capabilities, 1024B EEPROM, 2KB SRAM, 23 general purpose I/O lines, 32 general purpose working registers, three flexible timer/counters with compare modes, internal and external interrupts, serial programmable USART, a byte-oriented 2-wire serial interface, SPI serial port, a 6- channel 10-bit A/D converter (8-channels in TQFP and QFN/MLF packages), programmable watchdog timer with

internal oscillator and five software selectable power saving modes. The device operates between 1.8-5.5 volts. By executing powerful instructions in a single clock cycle, the device achieves throughputs approaching 1 MIPS per MHz, balancing power consumption and processing speed.

Hall Effect Based Flow Sensor- Effective water management involves supplying water according to the real requirement, and thus measuring water is very essential step in water management systems. There are many water flow measurement techniques as well as different types of water flow meters used to measure the volume of water flow in pipelines but these all are too costly. This article describes ideas for design and development of low cost automatic water flow meters, with the help of readily-available and low-cost water flow sensors. Accurate flow measurement is an essential step both in the terms of qualitative and economic points of view. Flow meters have proven excellent devices for measuring water flow, and now it is very easy to build a water management system using the renowned water flow sensor YF-S201. There is an integrated magnetic HallEffect sensor that outputs an electrical pulse with every revolution. The "YFS201 Hall Effect Water Flow Sensor" comes with three wires: Red/VCC (5-24V DC Input), Black/GND (0V) and Yellow/OUT (Pulse Output). By counting the pulses from the output of the sensor, we can easily calculate the water flow rate (in litre/hour - L/hr) using a suitable conversion formula.

GSM-A GSM module assembles a GSM modem with standard communication interfaces like RS-232 (Serial Port), USB etc., so that it can be easily interfaced with a computer or a microprocessor / microcontroller based system. The power supply circuit is also built in the module that can be activated by using a suitable adaptor. Controller will give amount of water usage by user in the form of decimal values to the GSM Modem. GSM modem then formats the value in the Message form. The MODEM needs AT commands, for interacting with processor or controller, which are communicated through serial communication. These commands are sent by the controller/processor. The MODEM sends back a result after it receives a command. Different AT commands supported by the MODEM can be sent by the processor/controller/computer to interact with the GSM cellular network.

2.3 Software Required.

IOT:-ThingSpeak is an open source Internet of Things (IoT) application and API to store and retrieve data from things using the HTTP protocol over the Internet or via a Local Area Network. ThingSpeak enables the creation of sensor logging applications, location tracking applications, and a social network of things with status updates.

3 WORKING

The Arduino flow meter works on the principle of the Hall Effect. According to which, a voltage difference is induced in a conductor transverse to the electric current and the

magnetic field perpendicular to it. Here, the Hall Effect is utilized in the flow meter using a small fan/propeller shaped rotor which is placed in the path of the liquid flowing. The liquid pushes against the fins of the rotor, causing it to rotate. The shaft of the rotor is connected to a Hall Effect sensor. It is an arrangement of a current flowing coil and a magnet connected to the shaft of the rotor, thus a voltage/pulse is induced as this rotor rotates. In this flow meter, for every liter of liquid passing through it per minute, it outputs about 4.5 pulses. This is due to the changing magnetic field caused by the magnet attached to the rotor shaft as seen in the picture below. We measure the number of pulses using an Arduino and then calculate the flow rate in liters per hour (L/hr) using a simple conversion formula.

Connecting the Arduino to the Flow Rate Sensor

The connections required for this flow rate sensor with respect to the Arduino is very minimal. There are only three wires coming from the flow rate sensor the 5V Vcc (Red wire), the GND (Black wire) and the signal/pulse (Usually yellow) line. Connect the Vcc and GND of the flow meter to the Arduino's Vcc and GND. The pulse line of the flow rate sensor is connected to the Arduino's digital pin 2.

Connecting Arduino with GSM

Here are two ways of connecting GSM module to arduino. In any case, the communication between Arduino and GSM module is serial. So we are supposed to use serial pins of Arduino (Rx and Tx). So if you are going with this method, you may connect the Tx pin of GSM module to Rx pin of Arduino and Rx pin of GSM module to Tx pin of Arduino. GSM Tx -> Arduino Rx and GSM Rx -> Arduino Tx. Now connect the ground pin of arduino to ground pin of gsm module. Now you can load different programs to communicate with gsm module and make it work. To send an SMS, we should set our GSM module to Text mode first. This is achieved by sending an AT Command "AT+CMGF=1" We send this command by writing this to SoftwareSerial port. To achieve this we use the Serial.println () function. My Serial.println writes data to software serial port (the Tx pin of our Software Serial - that is pin 10) and this will be captured by GSM module (through its Rx pin). After setting the GSM module to Text mode, we should the mobile number to which we shall send the SMS. This is achieved with AT command "AT+CMGS=\"+91xxxxxxxxx\"r" - where you may replace all x with the mobile number. In next step, we should send the actual content of SMS. The end of SMS content is identified with CTRL+Z symbol. The ASCII value of this CTRL+Z is 26. So we send a char (26) to GSM module using the line my Serial.println ((char) 26); Each and every AT command may be followed by 1 second delay. We must give some time for GSM module to respond properly. Once these commands are sent to GSM module, you shall receive an SMS in the set mobile number.

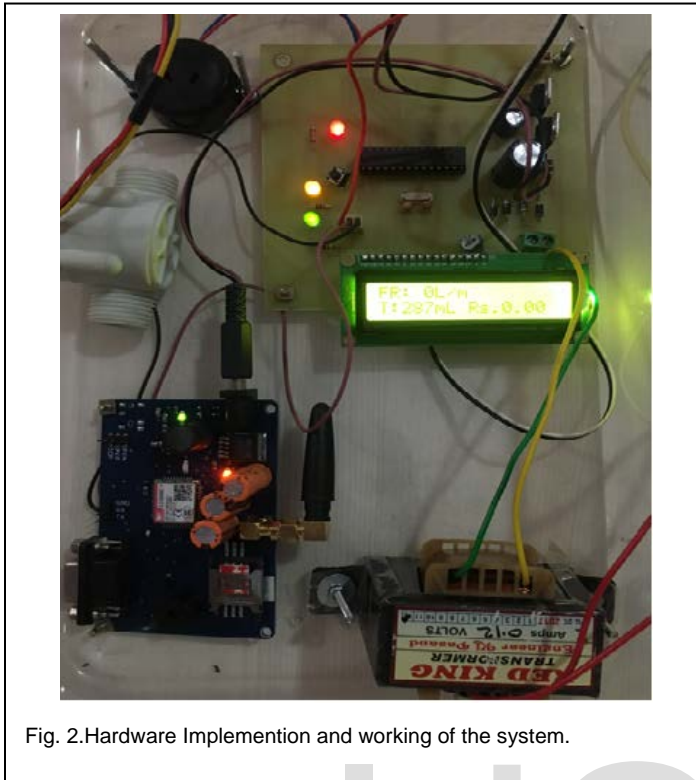

Fig. 2. Hardware Implementation and working of the system.

4 CONCLUSION

On the basis of analysis and design, the system provides a smart water meter with eco-friendly and energy efficient system. As the smart water meters are digitized and automated, high accuracy maintained by decreasing human efforts. Water theft can be avoided there are no mechanical parts that can be subjected to tamper. A hall effect sensor based water metering system was used for automated billing, eliminating the drawbacks of traditional water meter system. The flow meter is giving the reading under tolerable error. All the power equipment is working properly. The GSM module is working satisfactory by sending the bill amount and amount of water used to the fed mobile number.

ACKNOWLEDGMENT

This Project would not have been completed without the encouragement and support of many people who gave their precious time and encouragement throughout this period. First and foremost we would like to express our sincerest gratitude to our project guide Prof. A Panchal for her invaluable support, guidance, motivation and encouragement throughout the period this work was carried out.

We are also grateful to Prof. G.V. Dakhve Head of Department, Electronics and Telecommunication Engineering who gave us permission to use the project lab and give us all the necessary information for completion of project.

REFERENCES

- [1] Peter MWANGI, Elijah MWANGI, Patrick M Karimi " A low cost water meter System based on the Global System for Mobile communication". International Journal of computer application. (0975-8887) volume 142-No.12, May 2016.
- [2] ANJANA S1, SAHANA M N2, ANKHIT. K NATARANJAN4, K R SHOBHA5, "An IOT based 6Lo WPAN enabled experiment for water management", IEEE ANTS 2015.
- [3] Y.P. Joshi , M.B. Tadwal Implementation of GSM Based water meter step towards automatic billing published in IOSR Journal of Electronics and communication engineering Vol 9, Issue 4, version 1
- [4] Rob, K and Gabor ,M (2010). A perspective on radio frequency exposure associated with Residential Automatic meter reading Technology. California, USA Electrical power research Institute California.